



Total Solution Provider in Saw Device

SL10003AF

100.0MHz IF SAW Filter
3.07 MHz Bandwidth
Revision 0: 26. AUG. 2008



- Electrical Characteristics
 - Package Dimensions
 - Testing Environment
 - Frequency Characteristics
-

SAWNICS Inc.

460 Cheonheung-ri, Seonggeo-eup, Cheonan-si, Chungcheongnam-do, 330-836 / Korea.
Tel: +82 41 550 9372 / Fax: +82 41 550 9399 / www.sawnics.com

□ Electrical Characteristics

Maximum Ratings

Parameters Description	Unit	Minimum	Typical	Maximum
Operation Temperature Range	°C	-	45	-
Storage Temperature Range	°C	-20	-	70
Maximum DC Voltage	V	-	-	10
Maximum Input Power	dBm	-	-	28
Source Impedance (single ended) ⁽¹⁾	Ω	-	50	-
Load Impedance (single ended) ⁽¹⁾	Ω	-	50	-
Package type & size	F			
Length x Width	mm ²	-	34.7 x 12.6	-
Height	mm	-	-	5.05

Electrical Specification

Center Frequency (Fo)	MHz	-	100.5	-
Insertion Loss at Fo	dB	-	23.50	25.00
Group Delay Variation (Fo±1.44MHz)	ns	-	147	180
Phase Linearity (Fo±1.44MHz)	deg	-	6.5	10
Absolute Delay Time at Fo	us	-	4.78	4.85
Temperature Coefficient	ppm/°C	-	-0.03	-
Amplitude Ripple (Fo±1.44MHz)	dB	-	0.50	1.10
Bandwidth at -1dB	MHz	2.88	3.07	-
Bandwidth at -45dB	MHz	-	3.75	4.00
Input & Output Return Loss	dB	-	9	-
Triple transit attenuation	dBc	35	-	-
Relative Attenuation				
10MHz~95.0MHz	dBc	45	55	-
@98.49 MHz	dBc	40	56	-
@98.59 MHz	dBc	33	52	-
@102.41 MHz	dBc	33	52	-
@102.51 MHz	dBc	40	52	-
105.0MHz ~300.0MHz	dBc	45	47	-

Notes : (1) With Matching Network (Ref. Testing Environment Circuit as shown below).

Those impedances could be modified with different impedance values and/or structures, if necessary.

Package Dimensions

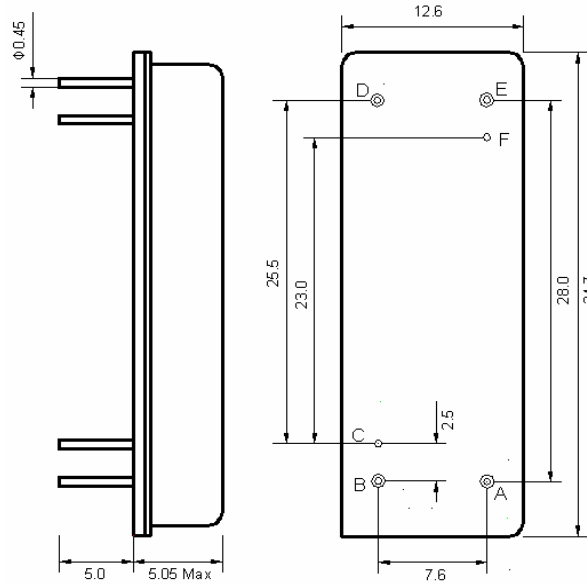

Pin Description	
B, C, E, F	Ground
A	Input
D	Output

Testing Environment

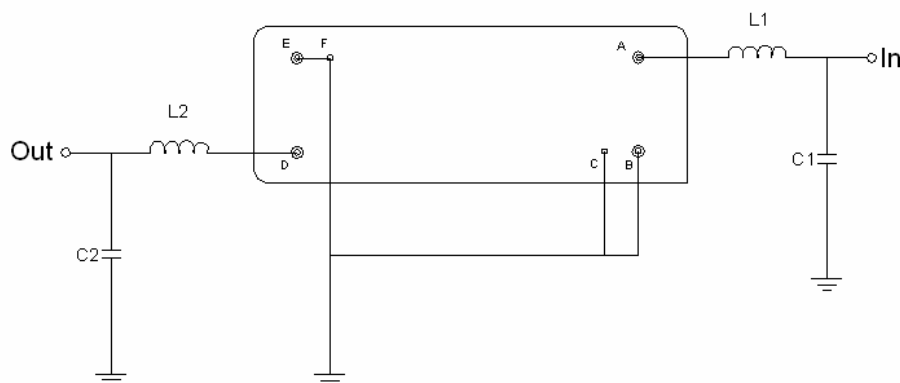

Test Fixture & Values	
Input	L1=100 nH Q >40, C1=75 pF
Output	L2=82 nH Q >40, C2=150 pF
Source/Load Impedance	50 Ω



Frequency Characteristics

Frequency Response

Bandwidth at -1.0 dB

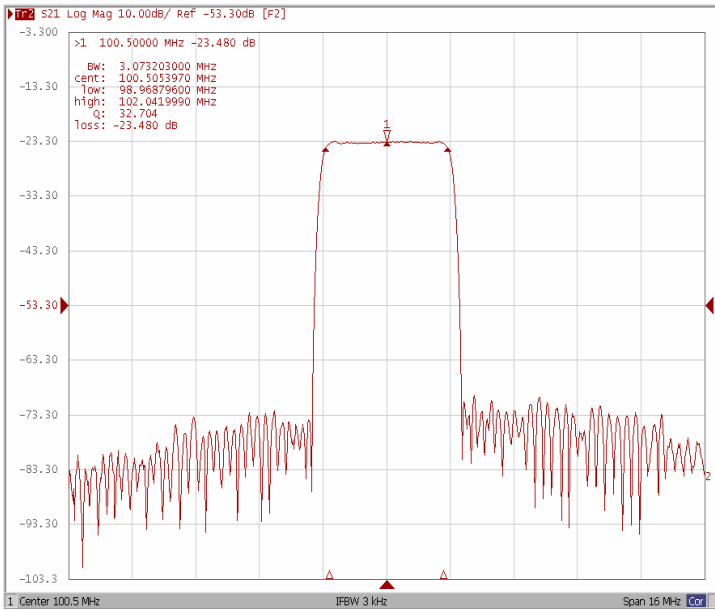

Bandwidth at -3.0 dB

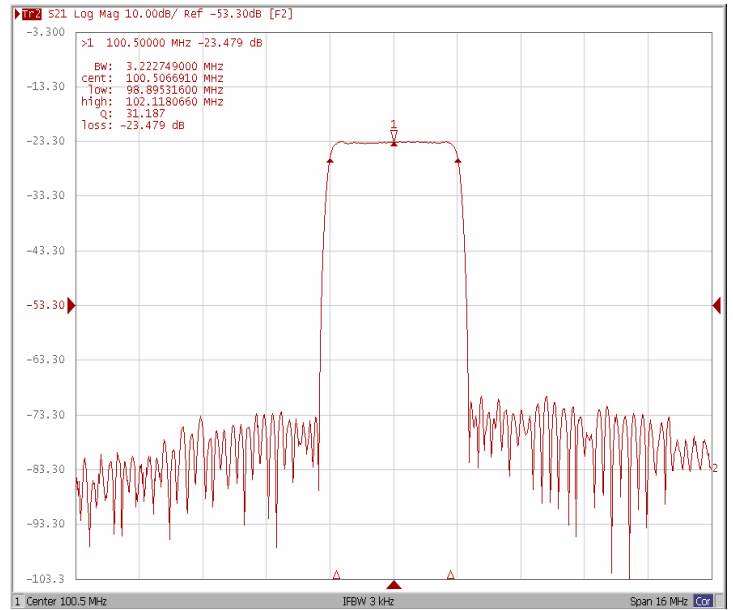

Bandwidth at -45.0 dB

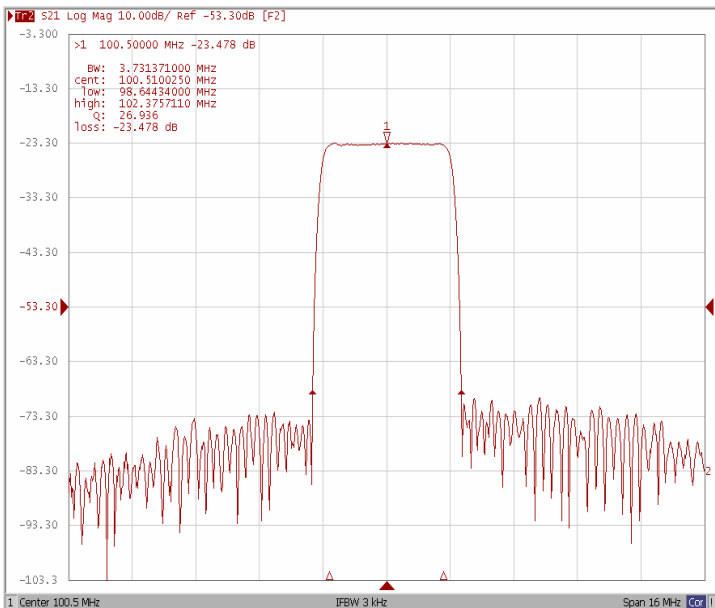

Relative Attenuation

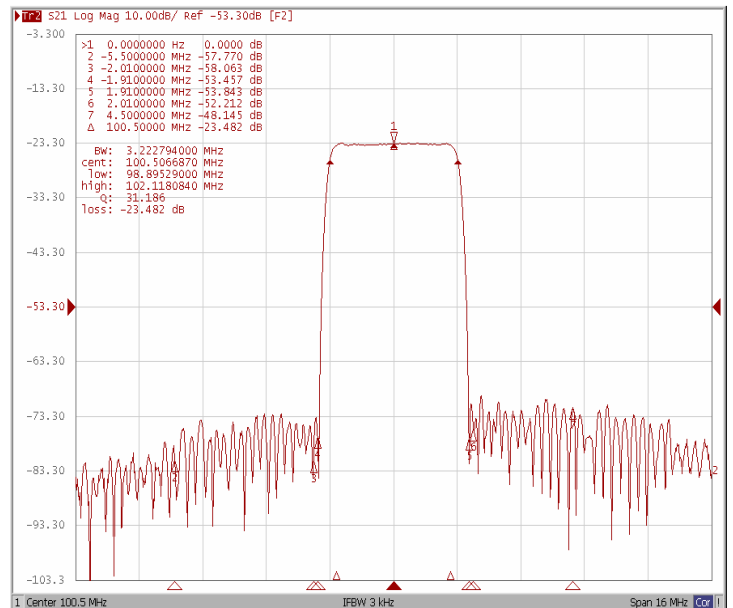



Frequency Characteristics

Frequency Response

Ripple Variation Fo±1.44MHz

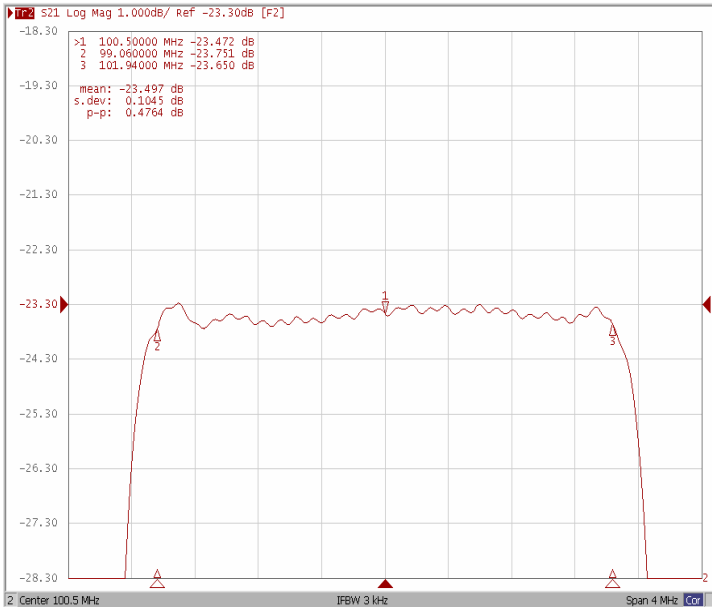

Group Delay Variation Fo±1.44MHz

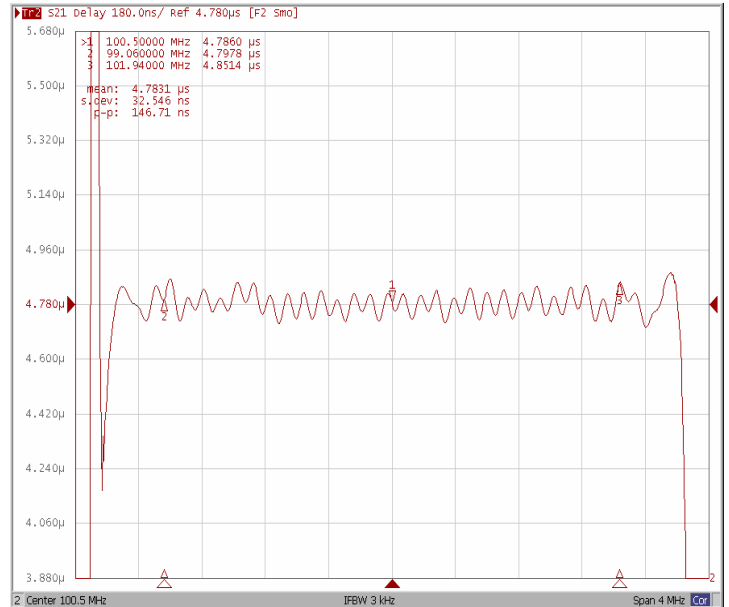

Phase Linearity Fo±1.44MHz

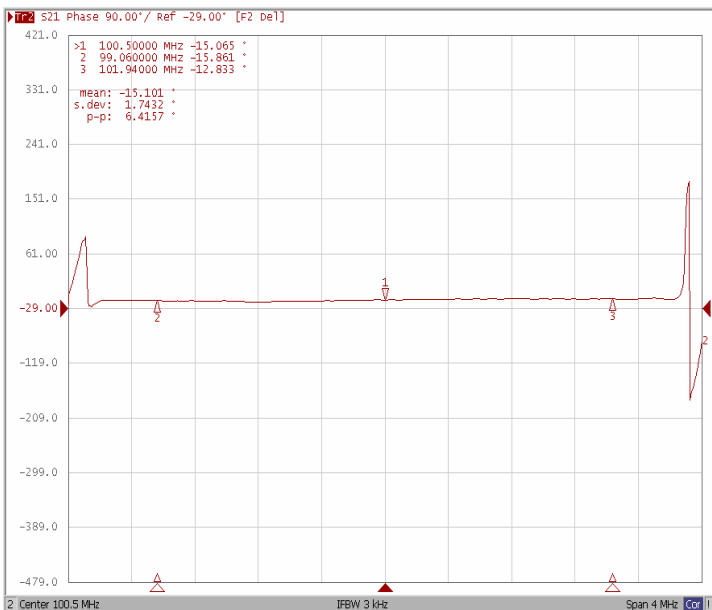

Smith Chart

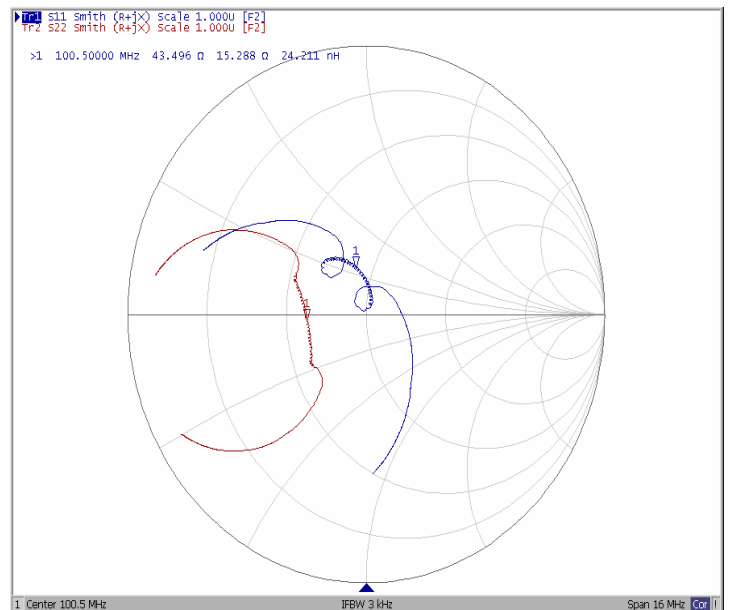



Frequency Characteristics

Frequency Response

Return Loss S11

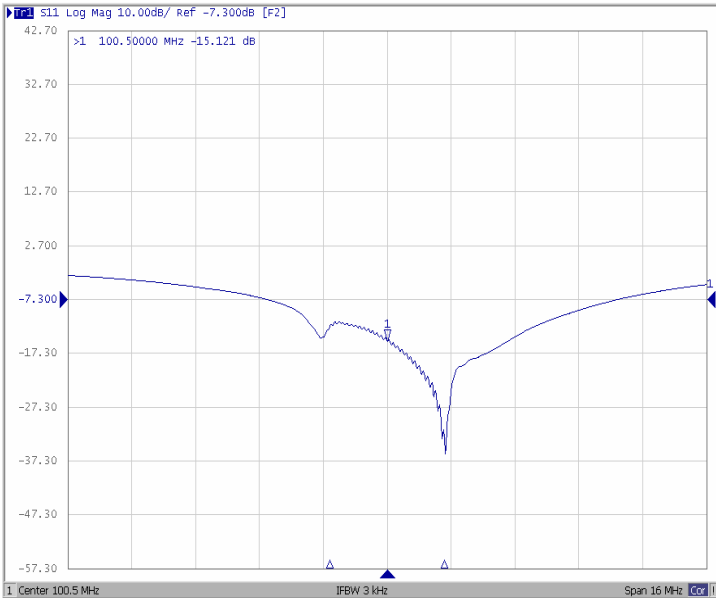

Return Loss S22

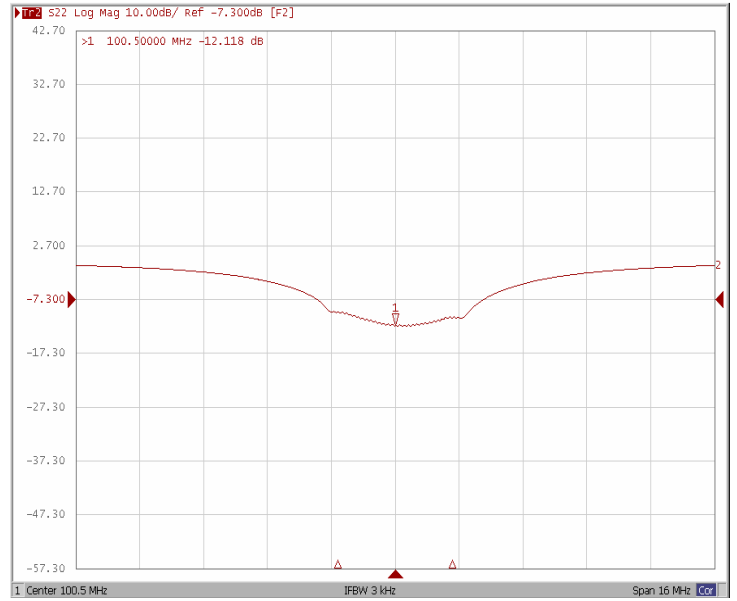

VSWR S11

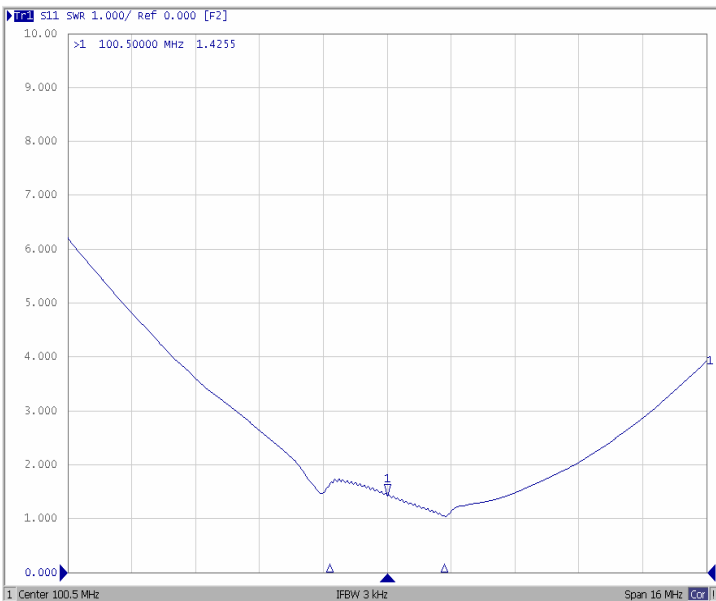

VSWR S22

